

TRITON

· T450i electric shower pump ·

ACTIVATE YOUR
FREE
PARTS AND LABOUR GUARANTEE
NOW
www.tritonshowers.co.uk
TRITON

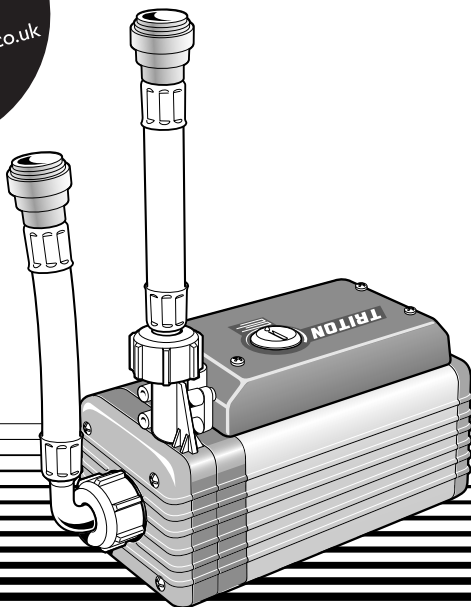

Installation and Operating Instructions

INSTALLERS PLEASE NOTE THESE INSTRUCTIONS ARE TO BE LEFT WITH THE USER

CONTENTS	Page
Plumbing and electrical notes	1
Introduction	2
Safety warnings	2
Key to main components	2
Site requirements	3
Siting of the pump	4
Fitting the pump	4 – 5
Variable speed control	6
Commissioning	6 – 7
Spare parts	8
Fault finding	9
Guarantee, service policy, etc.	rear cover

Due to continuous improvement and updating,
specification may be altered without prior notice.
Replacement parts can be ordered from Triton Customer
Service. See 'spare parts' for details.



1 PLUMBING NOTES

- 1.1 All installations must comply with the Local Water Company or Water Undertakers Byelaws.
- 1.2 Supply pipe must be flushed thoroughly to clear debris before connecting to the pump and shower (Byelaw 55).
- 1.3 DO NOT connect the pump unit to the mains cold water supply as it would damage the unit and also, the installation would be in breach of the guidance notes contained in '1' above.
- 1.4 DO NOT use excessive force when making connection to the flexible connector hose.
- 1.5 DO NOT turn on the electrical supply to the pump until the plumbing connections and commissioning procedure have been completed. *The pump must not be operated dry without water.*
- 1.6 DO NOT solder pipes or fittings within 300mm of the pump, as heat transfer can damage the components.
- 1.7 A dedicated cold water supply must be taken directly from the cold water cistern to the pump. This draw-off must be on the opposite side of the cistern to the float operated valve.
- 1.8 Standard gate valve MUST be fitted on the cold water supply to the pump as an independent means of isolating the water supplies should maintenance or servicing be necessary. DO NOT use stop taps or ball-o-fix type valves which restrict flow.
- 1.9 If the pump unit is installed on a common supply which feeds an adjacent tap, the maximum static inlet pressure for the unit will, under certain circumstances be exceeded. The action of closing the tap can cause a pulse in the supply pressure which may result in damage to the unit. This can be resolved by the installation of a suitably sized mini expansion vessel, sited as close as possible to the tap and pressurised to 0.5 bar.

2 ELECTRICAL NOTES

- 2.1 The installation must comply with BS 7671 'Requirements for electrical installations' (IEE wiring regulations) and Electrical Supply Company regulations. Ensure the incoming cold water supply to the pump is adequately earth bonded.
- 2.2 DO NOT turn on the electrical supply to the pump until the plumbing connections have been completed. *The pump must not be operated dry without water.*
- 2.3 The mains supply must be 230/240V, at 50Hz, connected to the pump via a double pole switched 3 Amp fused connection unit (not supplied) with a minimum 3mm contact separation gap in each pole.
- 2.4 In accordance with 'The Plugs and Sockets etc. (Safety) Regulations 1994', the pump is intended to be permanently connected to the fixed electrical wiring of the mains system.
- 2.5 Fuses do not give personal protection against electric shock.
- 2.6 It is strongly recommended to fit a 30mA residual current device (RCD). This may be part of the consumer unit or a separate unit.

INTRODUCTION

This book contains all the necessary fitting and operating instructions for your Triton T450i single impeller shower pump. Please read them carefully.

This product is rated at:
15 minutes on / 60 minutes off.

The shower pump has been designed for use with stored cold water and is intended to be installed with an instantaneous shower unit in areas subject to low pressure.

The installation must be carried out by a suitably competent person and in sequence of this instruction book.

Care taken during the installation will ensure a long and trouble free life from your unit.

Important: All plumbing connections must be completed before making the electrical connections.

Please read through the whole of this book before beginning your installation.

SAFETY WARNINGS

- a** Under no circumstances must this pump be connected to a mains cold water supply. Failure to comply will invalidate the guarantee.
- b** The shower pump **MUST NOT** be used if suspected of being frozen.
- c** This pump must be earthed.
- d** Switch off immediately at isolating switch if water ceases to flow during use.
- e** If it is intended to operate the unit outside the guidelines laid out in 'site requirements'.
- f** This pump is to be used for providing water to a shower only.

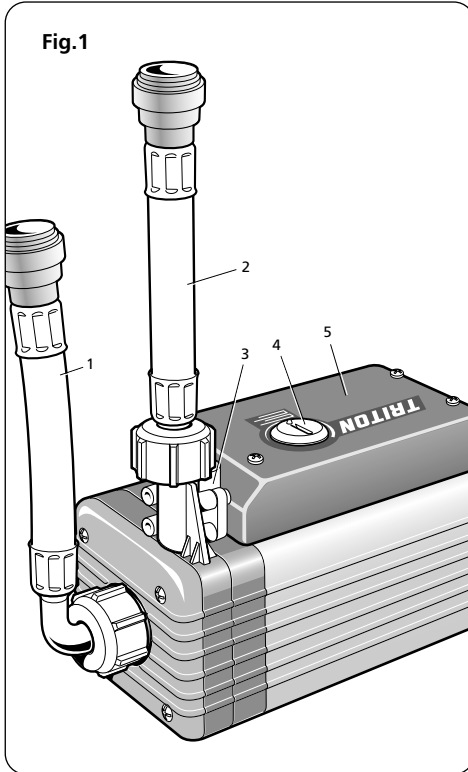

Fig.1

KEY TO MAIN COMPONENTS (Fig.1)

- 1 Inlet connector hose
- 2 Outlet connector hose
- 3 Integral flow switch
- 4 Variable speed control
- 5 PCB cover

In the interest of electrical safety a 30mA residual current device (RCD) should be installed in all UK electric and pumped shower circuits. This may be part of the consumer unit or a separate unit.

Electrical

WARNING: THE PUMP MUST BE EARTHED.

The pump must be connected to a 230/240V A.C. electrical supply from a ring main, via a double pole switch with at least 3mm contact separation. This can be a ceiling mounted pull cord switch in the shower room, or a wall mounted switch in an adjacent room.

The pump should be fused at 3 amps.

It is recommended that a suitable residual current device (RCD) is fitted in the electricity supply circuit to this appliance.

NOTE: The installation and wiring must comply with current I.E.E. Regulations.

When installed in any room containing a fixed bath or shower, the pump MUST be located and concealed inside a suitable cupboard, built-in unit or other enclosure, so that the pump cannot be sprayed with water, and such that a person using a fixed bath or shower cannot touch the pump without using tools.

DO NOT connect the pump electrical wiring to the shower unit.

SITING OF THE PUMP

WARNING: THE UNIT MUST NOT BE POSITIONED WHERE IT WILL BE SUBJECT TO FREEZING CONDITIONS.

The pump MUST ALWAYS be positioned BELOW the cold water cistern.

It is recommended that the cold water supply is taken from the opposite side of the cistern to the ballcock feed to prevent air entrapment in the supply.

Position the pump in a dry area and ensure it is accessible for any maintenance etc. that may be necessary.

Important: Ensure the ventilation slots on the underside of the pump are free from obstructions.

FITTING THE PUMP

Before commencing installation of the pump, ensure the site requirements have been fully complied with.

Also, please note the following:

- Pipework to precede wiring.
- All pipework must be a minimum of 15mm diameter.
- The pump must be positioned in a dry area, ideally in the linen/airing cupboard. It must be well ventilated and not covered with towels and sheets etc.
- Do not use with a combination water tank system unless the cold water storage tank has capacity of 114 litres (25 galls) or more.
- To assist in clearing air bubbles from the system avoid using sharp bends where possible. Flexible/swept fittings or formed pipework is recommended.
- Ensure that all water supplies are isolated before connection. A gate valve or full way lever valve must be fitted immediately prior to the pump. It is also advisable to fit a drain-off point on the lowest part of the system.
- NEVER use any form of soldered fittings on the shower pump as this will damage the unit and invalidate the guarantee.
- NEVER use solder within 300mm (12ins) of the pump or expose parts to a hot torch.
- Ensure mains electricity supply is SWITCHED OFF before commencing electrical connections.
- DO NOT OPERATE THE PUMP DRY.

NOTE: The pump motor has automatically resetting thermal overload protection.

Procedure

- a** Turn off mains water and electrical supplies and drain the cold water cistern.
- b** Position the pump horizontally (with the outlet port vertical) with the feet on a solid base so that it will not transmit vibration. NOTE: The pump MUST ONLY be placed in the horizontal position.

c Connect the inlet flexible connector to the inlet port of the pump ensuring the filter is in position (**fig.3**).

d Connect the outlet flexible connector to the outlet port of the pump.

e Connect the electric shower feed pipe to the outlet flexible push-in connector.

f At this stage, DO NOT connect the cold water supply from the cistern to the inlet flexible push-in connector. Wait until the commissioning procedure has been completed.

NOTE: Do not overtighten the connections on the pump ports and take care to prevent any system debris from entering the pump via the connectors.

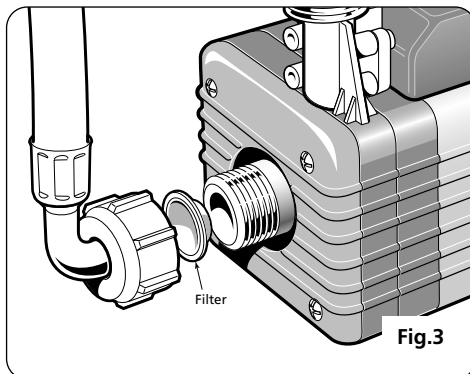

Fig.3

Wiring

g Remove the four retaining screws holding the PCB cover (**fig.4**). Lift the cover together with the variable speed control from the pump body.

h The 3 core cable from the mains electricity supply can now be connected to the terminal block situated on the PCB (**fig.5**). The size of cable to use must be a minimum of 0.75mm.

Ensure the terminal block screws are *fully tightened* and that no cable insulation is trapped under the screws.

NOTE: When connecting the earth cable to the earth post, take care NOT to overtighten the securing nut.

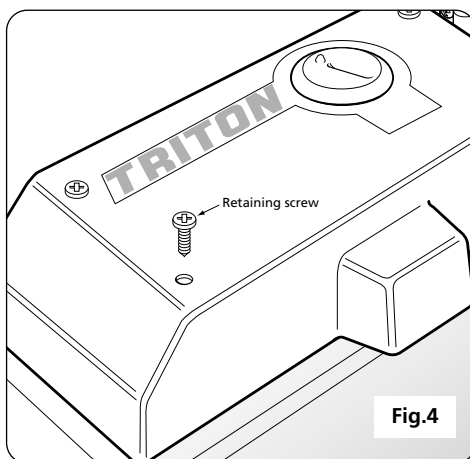

Fig.4

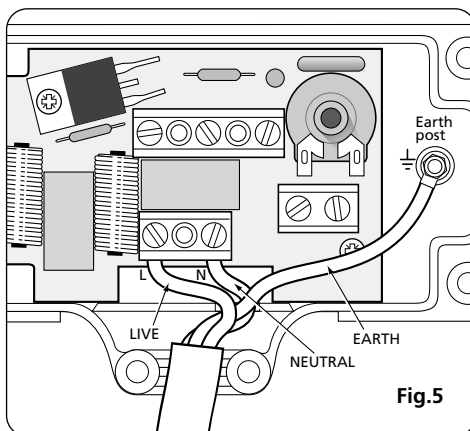
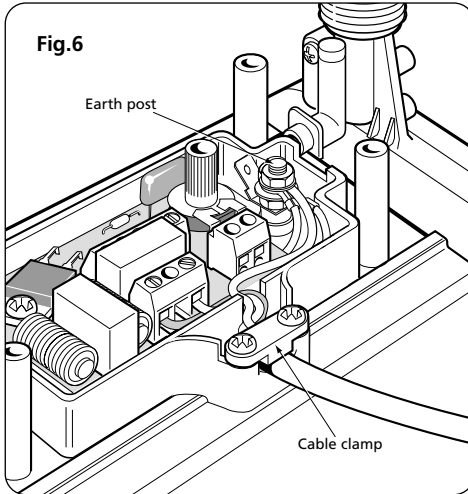

Fig.5



Important: Remove only the minimum necessary amount of conductor insulation when wiring to the terminal block.

The cable clamp must be used to secure the cable (**fig.6**).

NOTE: Before replacing the cover, ensure the potentiometer is rotated fully clockwise (**fig.7**) until a 'stop' is felt. Then ensure the speed control is positioned to '3' on the cover (**fig.8**).

Replace the PCB cover and variable speed control knob. Should the control knob have been detached from the cover, ensure the 'O' ring (**fig.9**) is correctly seated before replacing the control knob.

WARNING: Installation of this pump will break the earth continuity of the pipework installation. It is important that the earth be restored by cross bonding the pipework, in conformity with current I.E.E. regulations.

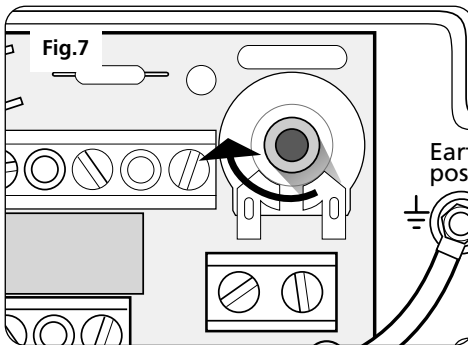

VARIABLE SPEED CONTROL

The variable speed control (**fig.10**) can be adjusted to select the optimum performance of the pump to suit personal preferences.

COMMISSIONING

Before the first operation of the shower pump, it is necessary to flush out any system debris from the installation. This operation must be carried out with the pump isolated from the electricity supply, and with the pump feed pipework from the cistern directed to waste by connecting a suitable length of hose.

- a Turn on the mains water supply to the storage cistern and open the isolation valve to the pump and allow the system to fill.
- b Allow water to flow to waste for two or three minutes to ensure any installation debris and air is completely flushed from the system.
- c Check the system pipework for leaks.
- d Close the isolation valve to the pump.
- e Remove the waste hose and connect the cistern supply pipework to the pump inlet flexible push-in connector. Re-open the isolation valve to the pump.
- f Switch on the mains electricity supply to the electric shower unit and turn on the shower (refer to the manufacturers instructions). Allow water to



flow under gravity from the sprayhead for a few minutes.

g Check the pipework for any leaks.

h Turn off the shower at shower control.

j Switch on the mains electricity supply to the pump.

k Start the shower again. The pump will operate and water will flow. Allow water to flow to waste for two or three minutes.

l Turn off the shower at shower control – the pump will switch off and the water will cease to flow.

m Switch off the electric supply to the pump and eliminate any leaks.

NOTE: If care has been taken to prevent any obvious debris entering the system, the above procedure should be adequate for normal operating conditions of the pump and shower. However, it may be advisable to also clean the filter in the inlet port of the pump as an extra precaution.

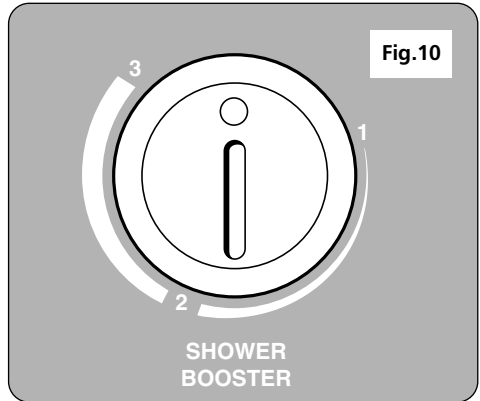
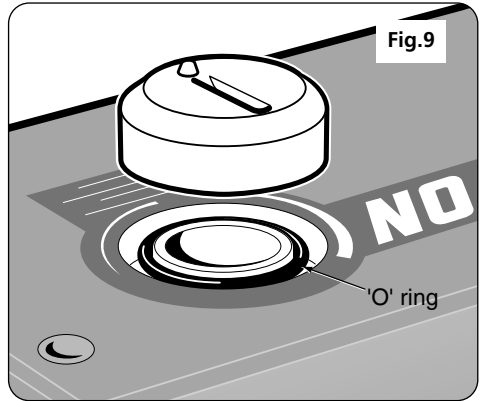

SPARE PARTS

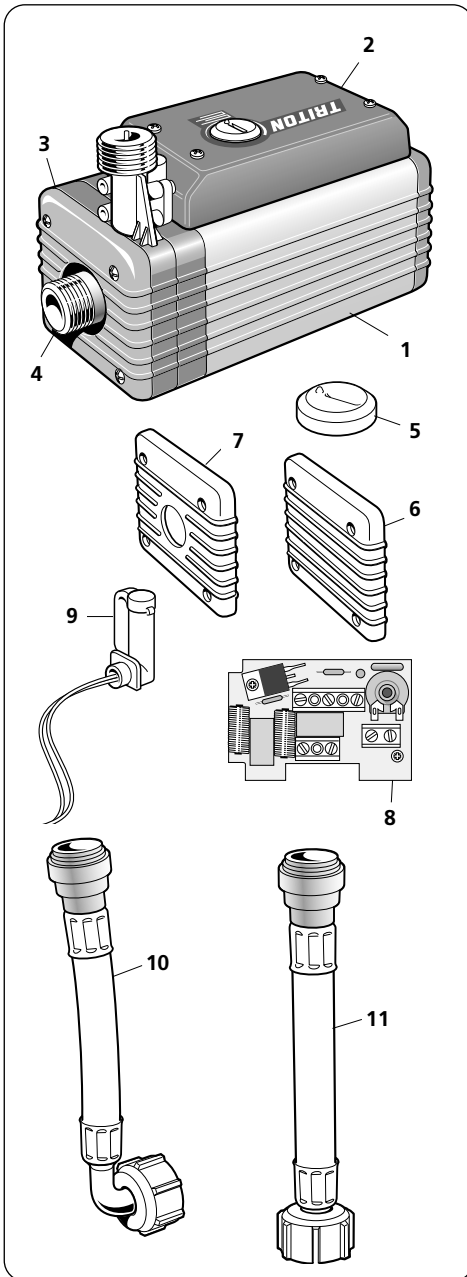

Ref	Description	Part No.
1	Pump assembly	T450i00M
2	Cover	7052286
3	Impeller housing	7051544
4	Pump inlet	7051543
5	Speed control knob	7051552
6	End cap – blank	7052311
7	End cap	7052310
8	PCB assembly	7072314
9	Flow switch assembly	82300590
10	Flexible connector inlet c/w filter	22004500
11	Flexible connector outlet c/w filter	22004510

FAULT FINDING

Problem/Symptom	Cause	Action/Cure
1 Pump motor does not operate.	1.1 Pump motor thermal overload protection activated.	1.1.1 Allow pump motor to cool and automatically reset. 1.1.2 Check pump is adequately ventilated.
	1.2 Mains electricity supply fault.	1.2.1 Blown fuse. Check supply, and renew or reset fuse. If it fails again, contact Customer Service. 1.2.2 Power cut. Check other appliances and if necessary contact local electricity Company.
	1.3 Loose wiring connections.	1.3.1 Check all connections and secure where necessary.
	1.4 Insufficient flow to operate flow switch.	1.4.1 Check isolating valve is fully open. 1.4.2 Check head of water. 1.4.3 Ensure inlet filter is clean.
	1.5 Faulty flow switch.	1.5.1 Replace switch. Contact Triton Customer Service for advice.
	1.6 Failed pump motor	1.6.1 Replace pump unit. Contact Triton Customer Service.
2 Poor or no water flow.	2.1 Pump motor not running.	2.1.1 See causes 1.1, 1.2, 1.3, 1.4, 1.5, and 1.6
	2.2 Pump or shower unit frozen.	2.2.1 Check for evidence of freezing. Contact Triton Customer Service for advice.
	2.3 Water turned off.	2.3.1 Check isolation valve and water supply.
	2.4 No water in cold storage cistern.	2.4.1 See 2.3.1
	2.5 Blocked flow switch.	2.5.1 Remove obstruction and flush out thoroughly.
	2.6 Blocked sprayhead on shower unit.	2.6.1 Clean sprayhead. Refer to separate instructions.
	2.7 Blocked filter.	2.7.1 Clean filter.
3 Pump does not switch off.	3.1 Faulty flow switch	3.1.1 Replace flow switch. Isolate electric supply to pump. Contact Triton Customer Service for advice.

Any maintenance or repair to the pump MUST be carried out by a suitably competent person

Service Policy

In the event of a complaint occurring, the following procedure should be followed:

- 1 Telephone Customer Service on: 0870 067 3333 (0845 762 6591 in Scotland and in Northern Ireland), having available the model number and power rating of the product, together with the date of purchase.
- 2 Triton Customer Service will be able to confirm whether the fault can be rectified by either the provision of a replacement part or a site visit from a qualified Triton service engineer.
- 3 If a service call is required the unit must be fully installed for the call to be booked and the date confirmed. In order to speed up your request, please have your postcode available when booking a service call.
- 4 It is essential that you or an appointed representative (who must be a person of 18 years of age or more) is present during the service engineer's visit and receipt of purchase is shown.
- 5 A charge will be made in the event of an aborted service call by you but not by us, or where a call under the terms of guarantee has been booked and the failure is not product related (i.e. scaling and furring, incorrect water pressure, pressure relief device operation, electrical installation faults).
- 6 If the product is no longer covered by the guarantee, a charge will be made for the site visit and for any parts supplied.
- 7 Service charges are based on the account being settled when work is complete, the engineer will then request payment for the invoice. If this is not made to the service engineer or settled within ten working days, an administration charge will be added.

Replacement Parts Policy

Availability: It is the policy of Triton to maintain availability of parts for the current range of products for supply after the guarantee has expired. Stocks of spare parts will be maintained for the duration of the product's manufacture and for a period of five years thereafter.

In the event of a spare part not being available a substitute part will be supplied.

Payment: The following payment methods can be used to obtain spare parts:

- 1 By post, pre-payment of pro forma invoice by cheque or money order.
- 2 By telephone, quoting credit card (MasterCard or Visa) details.
- 3 By website order, www.tritonshowers.co.uk

Triton Showers
Triton Road
Nuneaton
Warwickshire CV11 4NR

Triton is a division of Norcross Group (Holdings) Limited

TRITON STANDARD GUARANTEE

Triton guarantee this product against all mechanical and electrical defects arising from faulty workmanship or materials for a period of one year for domestic use only, from the date of purchase, provided that it has been installed by a competent person in full accordance with the fitting instructions.

Any part found to be defective during this guarantee period we undertake to repair or replace at our option without charge so long as it has been properly maintained and operated in accordance with the operating instructions, and has not been subject to misuse or damage.

This product must not be taken apart, modified or repaired except by a person authorised by Triton. This guarantee applies only to products installed within the United Kingdom and does not apply to products used commercially. This guarantee does not affect your statutory rights.

What is not covered:

- 1 Breakdown due to: *a)* use other than domestic use by you or your resident family; *b)* wilful act or neglect; *c)* any malfunction resulting from the incorrect use or quality of electricity, gas or water or incorrect setting of controls; *d)* faulty installation.
- 2 Repair costs for damage caused by foreign objects or substances.
- 3 Total loss of the product due to non-availability of parts.
- 4 Compensation for loss of use of the product or consequential loss of any kind.
- 5 Call out charges where no fault has been found with the appliance.
- 6 The cost of repair or replacement of pressure relief devices, showerheads, hoses, riser rails and/or wall brackets, isolating switches, electrical cable, fuses and/or circuit breakers or any other accessories installed at the same time.
- 7 The cost of routine maintenance, adjustments, overhaul modifications or loss or damage arising therefrom, including the cost of repairing damage, breakdown, malfunction caused by corrosion, furring, pipe scaling, limescale, system debris or frost.

Customer Service: ☎ 0870 067 3333

**Scottish and Northern Ireland
Customer Service:** ☎ 0845 762 6591

Trade Installer Hotline: ☎ 0870 067 3767
Fax: 0870 067 3334

www.tritonshowers.co.uk

E mail: technical@tritonshowers.co.uk

Extended Warranty AVAILABLE NOW. Call 0870 067 3333 for more details.